



Frigos 1 Door 29" Sandwich
Prep Table
SKU: FG-SWPT-29

- ★ **Spacious:** 6.7 cu ft capacity
- ★ **Durable:** Stainless steel exterior, painted aluminum interior
- ★ **Efficient:** Low energy usage (3.19 kW.h/24h)
- ★ **Convenient:** Self-closing doors, efficient LED lighting
- ★ **Certified:** ETL Electrical, ETL Sanitation, DOE
- ★ **Mobility:** Locking casters
- ★ **Powerful:** 1/6 HP compressor
- ★ **Sleek:** Silver finish, swing-style solid doors



Refrigerant	R290
Horsepower (HP)	1/6
Voltage (V)	115V/60hz
KW per 24h	3.19kw.h/24h
Wattage	327
Weight (lbs)	80
Shipping Weight (lbs)	94
Door Self Closed	Yes
Interior Material	Painted Aluminum
Exterior Material	Stainless Steel
Color	Silver
Door Style	Swing
Door Type	Solid
Compressor Location	Rear Mounted
Shelf Capacity (lbs)	85
Plug Type	NEMA 5-15P

Introducing our premium 29" sandwich prep table, the Frigos FG-SWPT-29. This meticulously designed unit delivers outstanding performance and reliability for your commercial kitchen. With precise dimensions of 29 inches in width, 30 3/8 inches in depth, and 45 3/8 inches in height, it provides ample space for your culinary needs.

Crafted with a robust stainless steel exterior and a clean, easy-to-maintain painted aluminum interior, this prep table combines durability with a hygienic appearance. The 6.7 cubic feet of storage capacity is complemented by its eight included pans, ideal for sandwich and salad preparation.

Item	Width (Inch)	Depth (Inch)	Height (Inch)
Exterior	29	30 3/8	45 3/8
Interior	24 3/4	25 3/8	28 3/4

Capacity (Cu Ft)	Number of Shelves	Number of Doors
6.7	1	1

- Crafted with a sturdy stainless steel exterior, a clean painted aluminum interior, and a dependable 304 stainless steel floor.
- Ample Storage: Includes one epoxy-coated shelf, capable of supporting up to 85 pounds.
- Superior Insulation: Features substantial 2-inch insulation for precise temperature control.
- High-Performance: Powered by a precise 1/6 HP compressor for top-tier reliability and efficiency.



Kitchen Pro Restaurant Equipment: info@gokpe.com | www.kitchenproequipment.com | T. 1-800-603-0033

Note: Specifications subject to change without notice.

Not recommended for use in non-commercial or residential settings.

The Frigos FG-SWPT-29 features energy-efficient components, with a 1/6 HP compressor operating at 115V/60Hz and using eco-friendly R290 refrigerant. It consumes minimal energy, costing only 3.19 kW.h/24h, ensuring long-term cost savings for your business.

This unit's single solid door is reversible for convenience and energy efficiency, sealing in freshness. The interior includes one sturdy shelf capable of holding up to 85 pounds. LED lighting is built in for clear visibility of your ingredients, ensuring efficient food preparation.

Hinge Location	Amps	Hertz	Temperature Range
right	2.9A	60Hz	33°F to 40°F
Phase	Shelves Size	Shelf Capacity (lbs)	Caster Size (Inch)
Single-phase	23.46 x 19	85	5"

Choose the Frigos FG-SWPT-29 for quality and reliability in your commercial kitchen. Whether you're in the foodservice industry or running a restaurant, this prep table ensures your ingredients stay fresh and at the right temperature, preserving their quality.

1 Door 29" Sandwich Prep Table SKU: FG-SWPT-29

The self-closing door adds convenience and saves energy by ensuring a proper seal at all times. Moving it around is effortless with four 5-inch casters that provide stability and mobility.



Invest in the future of your business with the Frigos FG-SWPT-29 sandwich prep table. It's a powerful, energy-efficient, and reliable addition to any kitchen, designed to meet your needs for years to come. Explore our range of prep tables and kitchen equipment to optimize your operations. Elevate your kitchen with Frigos.

Technical Data:

FRONT VIEW

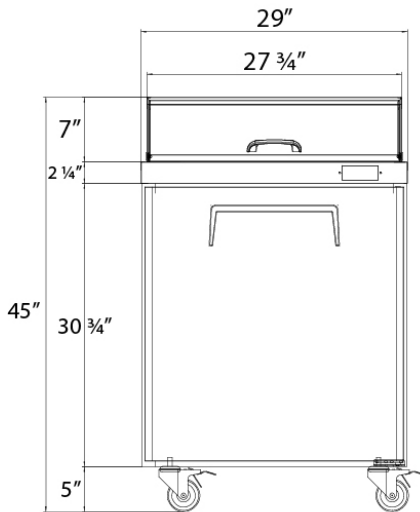

TOP VIEW

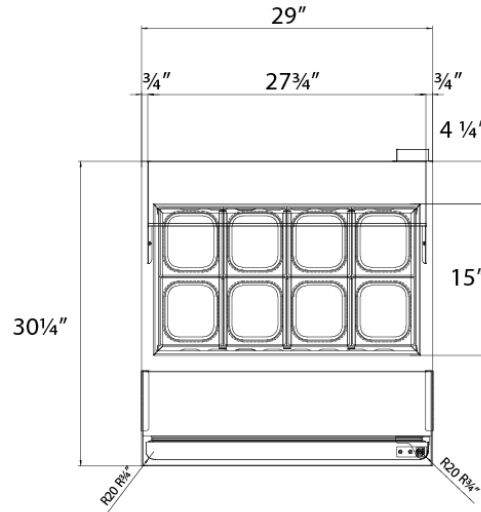

TOP VIEW

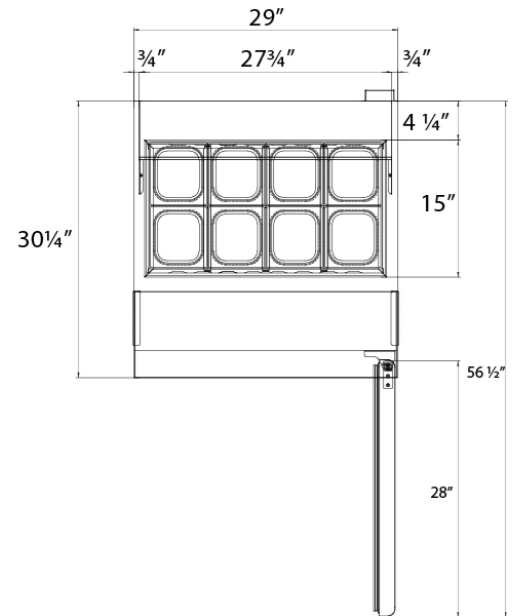

1 Door 29" Sandwich Prep Table SKU: FG-SWPT-29

Our FG-MR-3D-G merchandiser glass door refrigerator is certified by ETL for Electrical, ETL Sanitation, and DOE, meeting essential health and safety standards. Its stylish silver finish and swing-style solid glass door not only convey a professional appearance but also offer easy access to your products.



Warning: This product can expose you to chemicals including lead, which are known to the State of California to cause cancer, birth defects, or other reproductive harm. For more information, go to www.p65warnings.ca.gov.