



## Frigos 3 Door 80" Merchandiser Refrigerator

SKU: FG-MR-3D-G

- ★ Spacious: 70 cu ft capacity.
- ★ Durable: Stainless steel exterior, painted aluminum interior.
- ★ Efficient: Low energy use (6.260 kW.h/24h).
- ★ Convenient: Self-closing glass doors, efficient LED lighting.
- ★ Certified: ETL Listed, ETL Sanitation, DOE Certified.
- ★ Mobility: Locking casters.
- ★ Powerful: 3/8 HP compressor.
- ★ Sleek: Silver finish, swing-style glass doors.



<b>Refrigerant</b>	R290
<b>Horsepower (HP)</b>	3/8
<b>Voltage (V)</b>	115V
<b>KW per 24h</b>	6.26
<b>Wattage</b>	664
<b>Weight (lbs)</b>	270
<b>Shipping Weight (lbs)</b>	290
<b>Interior Material</b>	Painted Aluminum
<b>Exterior Material</b>	Stainless Steel
<b>Color</b>	Silver
<b>Door Style</b>	Swing
<b>Door Type</b>	Glass
<b>Compressor Location</b>	Bottom Mounted
<b>Shelf Capacity (lbs)</b>	85
<b>Plug Type</b>	NEMA 5-15P
<b>Reversible Doors</b>	Yes
<b>Features</b>	LED Light

Introducing our premium three-door commercial merchandiser glass door refrigerator, model FG-MR-3D-G, meticulously designed to deliver outstanding performance and reliability for your commercial kitchen. This merchandising glass door refrigerator offers a spacious interior with precise measurements of 80 inches in width, 33 1/2 inches in depth, and 83 inches in height, providing ample storage with a capacity of 70 cubic feet, perfect for showcasing your products.

Crafted with a robust stainless steel exterior and a clean, easy-to-maintain painted aluminum interior, this unit combines durability with a clean and hygienic appearance. The substantial 2-inch insulation, using Cyclopentane, ensures excellent temperature control, keeping your products fresh and enticing.

Item	Width (Inch)	Depth (Inch)	Height (Inch)
<b>Exterior</b>	80	33 1/2	83
<b>Interior</b>	76 1/8	27 3/4	61 1/2

Capacity (Cu Ft)	Number of Shelves	Number of Doors
70	12	3

- **Crafted:** Features a robust stainless steel exterior, a clean painted aluminum interior, and a dependable 304 stainless steel floor.
- **Storage:** Offers ample space with 12 epoxy-coated shelves, each capable of supporting up to 85 pounds.
- **Insulation:** Provides superior temperature control with substantial 2-inch insulation.
- **Performance:** Operates at peak efficiency with a high-powered 3/8 HP compressor, ensuring top-tier reliability and efficiency.



**Kitchen Pro Restaurant Equipment:** [info@gokpe.com](mailto:info@gokpe.com) | [www.kitchenproequipment.com](http://www.kitchenproequipment.com) | T. 1(800)603-0033

Note: Specifications subject to change without notice.

Not recommended for use in non-commercial or residential settings.

Equipped with twelve sturdy shelves, each capable of holding up to 85 pounds, you'll have plenty of space to display your merchandise effectively. The built-in LED lighting guarantees clear visibility of your products, attracting customers with its appealing presentation.

This commercial merchandiser glass door refrigerator is energy-efficient, utilizing eco-friendly R290 refrigerant and powered by a 3/8 horsepower compressor operating at 115V. It consumes minimal energy, costing only 6.260 kW per 24 hours, resulting in long-term cost savings.

Amps	Hertz	Door Self Closed	Temperature Range
9	60hz	Yes	32~44.6
Phase	Plastic Food Pans (inch)	Shelves size	Caster Size (Inch)
Single-phase	12" x 20"	25"x24.5"	5"

The Frigos brand is synonymous with quality, and this merchandiser glass door refrigerator upholds that reputation. Whether you're in the foodservice industry or running a commercial kitchen, you can trust this unit to keep your merchandise at the right temperature, preserving its quality and attractiveness.

### 3 Door 80" Merchandiser Refrigerator SKU: FG-MR-3D-G

The self-closing glass door adds convenience and saves energy by ensuring a proper seal at all times. Moving it around is effortless with bottom-mounted, locking 5-inch casters that provide stability and mobility.



Invest in the future of your business with our FG-MR-3D-G three-door merchandiser glass door refrigerator, perfect for your merchandising needs. It's a powerful, energy-efficient, and reliable addition to any kitchen, designed to meet your needs for years to come. Explore our selection of commercial merchandising glass door refrigerators and other equipment to optimize your business operations. Elevate your offerings with Frigos.

## Technical Data:

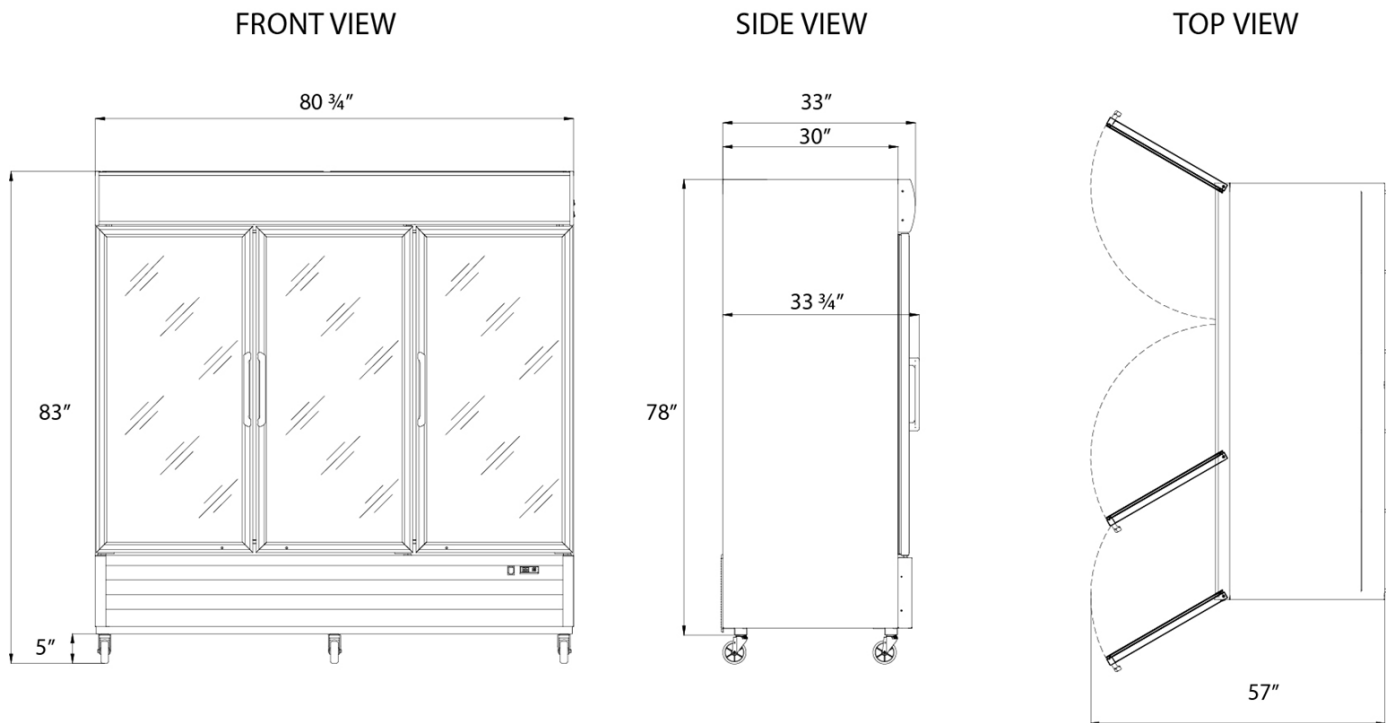

### 3 Door 80" Merchandiser Refrigerator SKU: FG-MR-3D-G

Our FG-MR-3D-G merchandiser glass door refrigerator is certified by ETL for Electrical, ETL Sanitation, and DOE, meeting essential health and safety standards. Its stylish silver finish and swing-style solid glass door not only convey a professional appearance but also offer easy access to your products.



**Warning:** This product can expose you to chemicals including lead, which are known to the State of California to cause cancer, birth defects, or other reproductive harm. For more information, go to [www.p65warnings.ca.gov](http://www.p65warnings.ca.gov).