



Frigos 1 Door 27" Merchandiser Refrigerator

SKU: FG-MR-1D-G

- ★ Spacious: 19.2 cu ft capacity
- ★ Durable: Stainless steel exterior, painted aluminum interior
- ★ Efficient: Low energy usage (1.704 kW.h/24h)
- ★ Convenient: Self-closing glass door, efficient LED lighting
- ★ Certified: ETL Listed, ETL Sanitation, DOE Certified
- ★ Mobility: Bottom-mounted, locking casters
- ★ Powerful: 1/6 HP compressor
- ★ Sleek: Silver finish, swing-style glass door



Refrigerant	R290
Horsepower (HP)	1/6
Voltage (V)	115V
KW per 24h	1.704
Wattage	327
Weight (lbs)	120
Shipping Weight (lbs)	130
Interior Material	Painted Aluminum
Exterior Material	Stainless Steel
Color	Silver
Door Style	Swing
Door Type	Glass
Compressor Location	Bottom Mounted
Shelf Capacity (lbs)	85
Plug Type	NEMA 5-15P
Reversible Doors	Yes
Features	LED Light

Introducing our premium one-door commercial merchandiser glass door refrigerator, model FG-MR-1D-G, meticulously designed to deliver outstanding performance and reliability for your commercial kitchen. This merchandising glass door refrigerator offers a spacious interior with precise measurements of 27 inches in width, 33 1/2 inches in depth, and 83 inches in height, providing ample storage with a capacity of 19.2 cubic feet, perfect for showcasing your products.

Crafted with a robust stainless steel exterior and a clean, easy-to-maintain painted aluminum interior, this unit combines durability with a clean and hygienic appearance. The substantial 2-inch insulation, using Cyclopentane, ensures excellent temperature control, keeping your products fresh and enticing.

Item	Width (Inch)	Depth (Inch)	Height (Inch)
Exterior	27	33 1/2	83
Interior	22 3/8	27 3/4	61 1/2

Capacity (Cu Ft)	Number of Shelves	Number of Doors
19.2	3	1

- **Crafted:** Durable stainless steel exterior, easy-to-maintain painted aluminum interior, dependable 304 stainless steel floor.
- **Storage:** Offers ample space with 3 epoxy-coated shelves, each supporting up to 85 pounds.
- **Insulation:** Superior 2-inch insulation ensures precise temperature control.
- **Performance:** Driven by a high-powered 1/6 HP compressor, delivering top-tier reliability and efficiency.



Kitchen Pro Restaurant Equipment: info@gokpe.com | www.kitchenproequipment.com | T. 1-800-603-0033

Note: Specifications subject to change without notice.

Not recommended for use in non-commercial or residential settings.

Equipped with three sturdy shelves, each capable of holding up to 85 pounds, you'll have plenty of space to display your merchandise effectively. The built-in LED lighting guarantees clear visibility of your products, attracting customers with its appealing presentation.

This commercial merchandiser glass door refrigerator is energy-efficient, utilizing eco-friendly R290 refrigerant and powered by a 1/6 horsepower compressor operating at 115V. It consumes minimal energy, costing only 1.704 kW per 24 hours, resulting in long-term cost savings.

Amps	Hertz	Door Self Closed	Temperature Range
3.5	60hz	Yes	32~44.6
Phase	Plastic Food Pans (inch)	Shelves size	Caster Size (Inch)
Single-phase	12" x 20"	21.5"x25.7"	5"

The Frigos brand is synonymous with quality, and this sandwich salad prep table refrigerator upholds that reputation. Whether you're in the foodservice industry or running a commercial kitchen, you can trust this unit to keep your salad and sandwich ingredients at the right temperature, preserving their quality.

1 Door Merchandiser Refrigerator SKU: FG-MR-1D-G

The self-closing glass door adds convenience and saves energy by ensuring a proper seal at all times. Moving it around is effortless with bottom-mounted, locking 5-inch casters that provide stability and mobility.



Invest in the future of your business with our FG-MR-1D-G one-door merchandiser glass door refrigerator, perfect for your merchandising needs. It's a powerful, energy-efficient, and reliable addition to any kitchen, designed to meet your needs for years to come. Explore our selection of commercial merchandising glass door refrigerators and other equipment to optimize your business operations. Elevate your offerings with Frigos.

Technical Data:

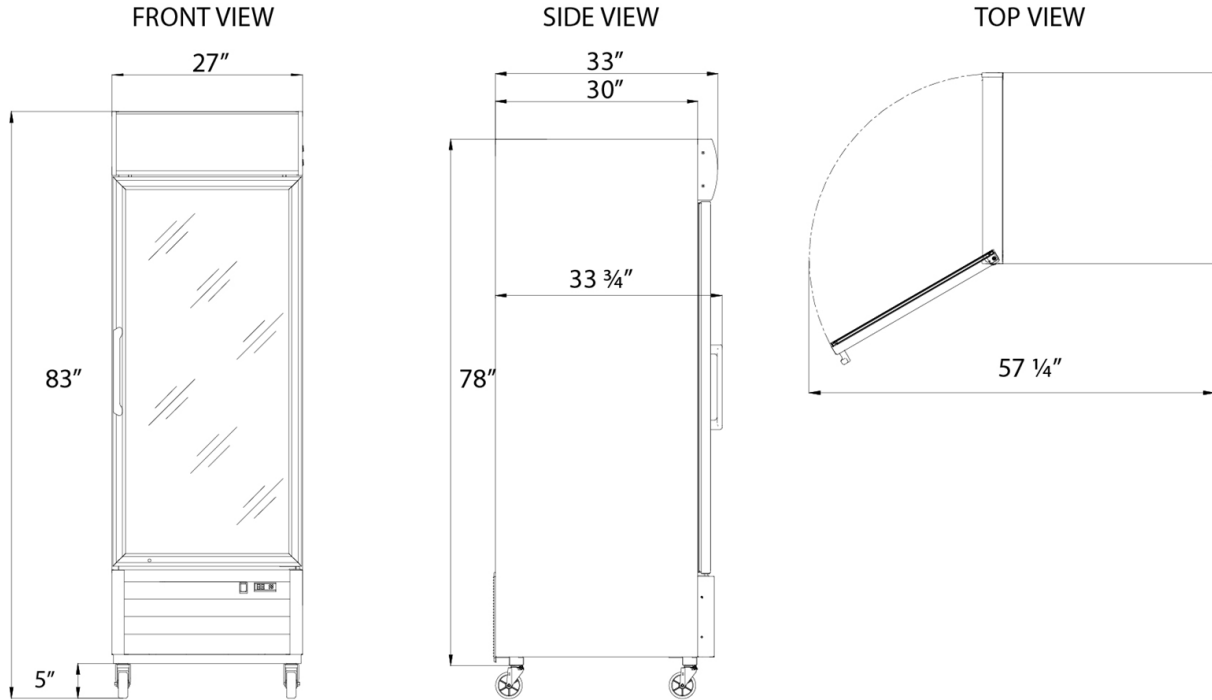

1 Door Merchandiser Refrigerator SKU: FG-MR-1D-G

Our FG-MR-1D-G merchandiser glass door refrigerator is certified by ETL for Electrical, ETL Sanitation, and DOE, meeting essential health and safety standards. Its stylish silver finish and swing-style solid glass door not only convey a professional appearance but also offer easy access to your products.



Warning: This product can expose you to chemicals including lead, which are known to the State of California to cause cancer, birth defects, or other reproductive harm. For more information, go to www.p65warnings.ca.gov.