

GLASS DOOR MERCHANDISER FREEZER SWING DOORS

Project Name: _____

Project Location: _____

Model #: _____ Quantity: _____

Available Warehouse: _____

EM Series

Model: EMGF69



Refrigeration System

- Bottom mounted, self-contained and retractable condensing unit uses environmentally friendly R404A* refrigerant with zero (0) Ozone Depletion Potential (ODP) and EPA compliant R290 refrigerant with zero (0) Ozone Depletion Potential (ODP) and three (3) Global Warming Potential (GWP). R290 condensing units are replaceable and require no on-site brazing. *Ask about alternative refrigerant.
- PSC evaporator fan motors for R404A models. Electronically commutated (ECM) fan motors for R290 models.
- Airflow guard ensures optimal circulation of cold air. R290 models include full-length air duct system.
- Time-initiated and temperature-terminated hot gas defrost cycle saves on energy.
- Large capacity, corrosion-resistant condenser and evaporator coils.
- Self-maintaining, energy-efficient condensate drain pan requires no external drains or electric heaters.
- High performance condenser fan motors ensure efficient compressor ventilation. R290 models use auto-reverse condenser fan motors which also support condenser coil cleaning. Refer to owner's manual for full maintenance instructions.
- Removable and washable condenser coil air filter for R404A models. R290 models do not require condenser coil air filters.
- Pressure relief devices allow smooth access to cabinet interior when reopening doors.
- Pre-wired power cord without plug, 230V/60Hz/1Ph.

Cabinet Construction

- Heavy duty white coated steel interior / exterior.
- Open spaced interior with no walls between compartments.
- Stainless steel floor interior has rounded corners and detachable drain plug for ease of cleaning.
- 2.5" thick high density polyurethane insulation.
- Six 5" swivel casters with locks on front set and three leg stabilizers.

Lighting

- Shielded LED bar lighting with on/off switch provides bright, high color illumination at lower heat output.

Doors

- Low emissivity double glass panes reflect UV rays for efficient cooling.
- Matte finish aluminum door frames.
- Frame heaters prevent exterior moisture build up.
- Defroster strips keep glass planes clear and fog-free.
- Self-closing with adjustable torsion system for a positive seal.
- Snap-in magnetic door gasket make cleaning and replacement an easy process.
- High strength, die-cast door handles.
- Pre-installed door locks keep your items safe from theft.

Shelving

- Four epoxy coated, steel wire shelves with airflow guard per section.
- Height adjustable stainless steel clips.

Temperature Control

- Multi-function digital controller with easy to read LED display.
- Factory preset temperature, -4°F. Temperature setting range from -10°F to 54°F.

Options

- Additional shelving.
- 3" swivel casters with locks.
- 3.5" – 6" height-adjustable and interchangeable legs.

Operating temperature range is -10°F ~ 54°F



**5 YEAR Compressor
3 YEAR Parts & Labor**



Please visit our website for updated Energy Efficiency information

Ref/ Frz/Dual	Doors	Capacity Cu. Ft.	Shelves	Refrigerant	HP	Power V-Hz-Ph	Amps	Crated Weight	Exterior Dimensions		
									L	D	H*
FRZ	3	69	12	R-404A/R-290	1-1/4 x 2	230-60-1	11.2	1125 lbs (510kg)	74.75" (1899mm)	31.625" (803mm)	80.125" (2035mm)

(†)Based on evaporating temperature of 23°F (-5°C) & condensing temperature of 131°F (55°C). (►) Product capacity is calculated based on standard industry figures. (✳) Reference plan view for clarification on caster/unit height. If dimensions and capacity are critical, please contact Everest Refrigeration. Blizzard R290 replacement is at the sole discretion of Everest Refrigeration. Specifications subject to change without notice.

GLASS DOOR MERCHANDISER FREEZER SWING DOORS

EM Series Model: EMGF69

DIMENSIONAL DATA

External Dimensions	L	74.75" (1899mm)
	D	31.625" (803mm)
	H*	80.125" (2035mm)
Crated Weight		1125 lbs. (510kg)
Doors/Drawers/Lids		3
Max Weight Support (LBS)		-

STORAGE DATA

Net Capacity Cu. Ft. ▶	69
Shelves	12
Barrels	-
20 oz. Bottles	-
12 oz. Bottles	-
12 oz. Cans	-
8" Mugs	-
# of Pans (Top)	-
# of Pans (Drawer)	-
Dividers	-
Trays	-

ELECTRICAL DATA

Voltage	230-60-1
Full Load Amperage	11.2A
Feed Wires with Ground	3
Cord Length	9ft
NEMA Plug Type	N/A

REFRIGERATION DATA

Compressor Mounting	Bottom
Refrigerant	R-404A/R-290
Compressor HP	1-1/4 x 2
BTU/HR †	5441 x 2

KEY

D	Door	R	Refrigerator
L	Lid	REF	Refrigerator
H	Half Door	F	Freezer
FD	Full Door	FRZ	Freezer
SD	Solid Door	DUAL	REF/FRZ Combo
GD	Glass Door	DR	Drawer

	Elevation	Right	Plan	3D	Back

PLAN VIEW

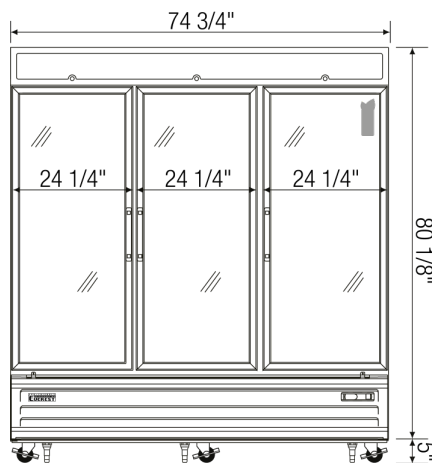

FRONT

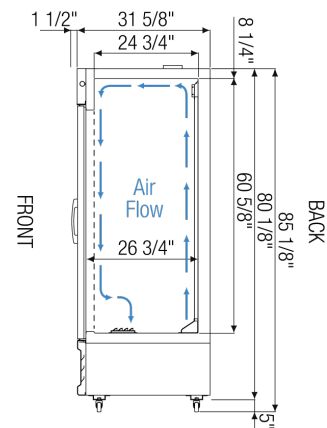

R290 models

SIDE

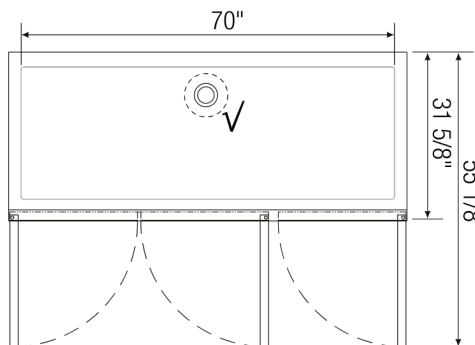

TOP

ACCESSORIES & OPTIONS

Part Number	Description
Additional Shelving	Contact Everest Refrigeration for more information.
AJL03-00	Interchangeable Leg for Caster
CASA3-02	3" Overall Height Caster Assembly - (3) Front (3) Rear

(†) Based on evaporating temperature of 23°F (-5°C) & condensing temperature of 131°F (55°C). (▶) Product capacity is calculated based on standard industry figures. (✳) Reference plan view for clarification on caster/unit height. If dimensions and capacity are critical, please contact Everest Refrigeration. Blizzard R290 replacement is at the sole discretion of Everest Refrigeration. Specifications subject to change without notice.