

## EBC Series Model: EBC37



### Refrigeration System

- Side mounted, self-contained and fully detachable Blizzard R290 condensing unit uses environmentally friendly, EPA-compliant R290 refrigerant with zero (0) Ozone Depletion Potential (ODP) and three (3) Global Warming Potential (GWP). Blizzard R290 is easily replaceable and requires no on-site brazing.
- Electronically commutated (ECM) fan motors achieve rapid cooling with less energy consumption.
- Full-length air duct system ensures optimal circulation of cold air.
- Time-initiated and temperature-terminated auto defrost cycle for seamless operation.
- Large capacity, corrosion-resistant condenser and evaporator coils.
- Self-maintaining, energy-efficient condensate drain pan requires no external drains or electric heaters.
- High performance, auto-reverse condenser fan motor supports compressor ventilation and condenser coil cleaning. Refer to owner's manual for full maintenance instructions.
- Pre-wired and ready to plug, 115V/60Hz/1Ph, NEMA 5-15P.

### Cabinet Construction

- Heavy duty stainless steel countertop and rails with textured laminate, black vinyl exterior.
- Open spaced interior with no walls between compartments.
- Galvanized steel interior.
- 1 3/4" thick high density polyurethane insulation.
- Built-in caster thread receptacles for all models.

### Lighting

- Shielded LED bar lighting with on/off switch provides bright, high color illumination at lower heat output.

### Bottle Cap Opener

- Front mounted bottle cap opener and cap catcher are removable for ease of cleaning.

### Lids

- Heavy duty stainless steel exterior and galvanized steel interior.
- 3/4" thick high density polyurethane insulation.
- Removable ratchet locks keep your items safe from theft.

### Shelving

- Horizontal epoxy coated, steel wire shelves for bottom air circulation (see table for quantity).
- Vertical epoxy coated, steel wire bin dividers (see table for quantity).

### Temperature Control

- Multi-function digital controller with easy to read LED display.
- Factory preset temperature, 35°F.
- Temperature setting range from 33°F to 54°F.
- Audible overheat protection alarm for compressor and condenser coil.

### Options

- Additional bin dividers.
- 3" or 5" swivel casters with locks.
- 3.5" – 6" height-adjustable and interchangeable legs.

 **Operating temperature range is 33°F ~ 54°F**



**5 YEAR Compressor**  
**3 YEAR Parts & Labor**



Please visit our website for updated Energy Efficiency information

Ref/ Frz/Dual	Lids	Capacity			Dividers	Shelves	Refrigerant	HP	Power V-Hz-Ph	Amps	Crated Weight	Exterior Dimensions		
		Cu. Ft.	12 oz. Cans	12 oz. Bottles								L	D	H*
REF	1	11	264	348	2	1	R-290	1/4+	115-60-1	3.5	197 lbs (89kg)	36.75" (933mm)	26.75" (679mm)	33.75" (857mm)

(†)Based on evaporating temperature of 23°F (-5°C) & condensing temperature of 131°F (55°C). (►) Product capacity is calculated based on standard industry figures. (✳) Reference plan view for clarification on caster/unit height. If dimensions and capacity are critical, please contact Everest Refrigeration. Blizzard R290 replacement is at the sole discretion of Everest Refrigeration. Specifications subject to change without notice.

# HORIZONTAL BOTTLE COOLER

## EBC Series Model: EBC37

### DIMENSIONAL DATA

External Dimensions	L	36.75" (933mm)
	D	26.75" (679mm)
	H*	33.75" (857mm)
Crated Weight		197 lbs. (89kg)
Doors/Drawers/Lids		1
Max Weight Support (LBS)		-

### STORAGE DATA

Net Capacity Cu. Ft. ▶	11
Shelves	1
Barrels	-
20 oz. Bottles	-
12 oz. Bottles	264
12 oz. Cans	348
8" Mugs	-
# of Pans (Top)	-
# of Pans (Drawer)	-
Dividers	2
Trays	-

### ELECTRICAL DATA

Voltage	115-60-1
Full Load Amperage	3.5A
Feed Wires with Ground	3
Cord Length	9ft
NEMA Plug Type	 NEMA 5-15P

### REFRIGERATION DATA

Compressor Mounting	Side
Refrigerant	R-290
Compressor HP	1/4+
BTU/HR †	1926

### KEY

D	Door	R	Refrigerator
L	Lid	REF	Refrigerator
H	Half Door	F	Freezer
FD	Full Door	FRZ	Freezer
SD	Solid Door	DUAL	REF/FRZ Combo
GD	Glass Door	DR	Drawer

	Elevation	Right	Plan	3D	Back

### PLAN VIEW

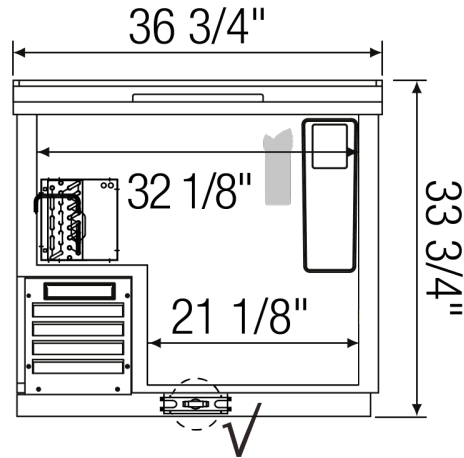

FRONT

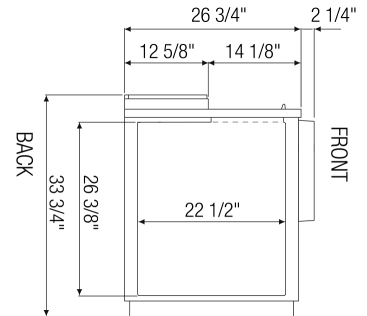

SIDE

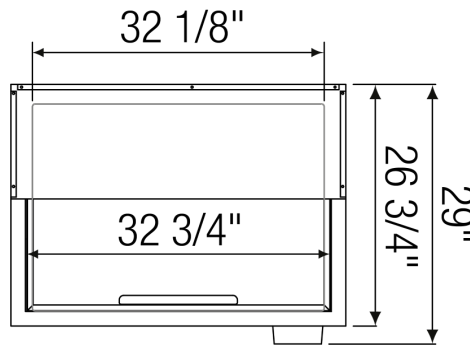

TOP

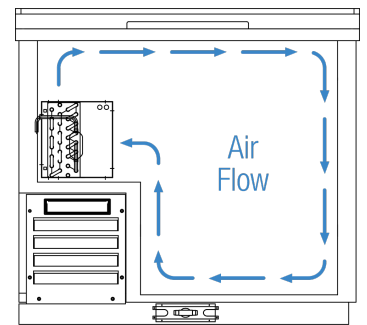

AIRFLOW

### ACCESSORIES & OPTIONS

Part Number	Description
AJL03-00	Interchangeable Leg for Caster
BCP01-01	24-1/2" x 19-13/16" (622mm x 503mm) Epoxy Coating Bottle Cooler
CASA3-01	3" Overall Height Caster Assembly - (2) Front (2) Rear
CASA5-01	5" Overall Height Caster Assembly - (2) Front (2) Rear

(†) Based on evaporating temperature of 23°F (-5°C) & condensing temperature of 131°F (55°C). (▶) Product capacity is calculated based on standard industry figures. (✖) Reference plan view for clarification on caster/unit height. If dimensions and capacity are critical, please contact Everest Refrigeration. Blizzard R290 replacement is at the sole discretion of Everest Refrigeration. Specifications subject to change without notice.