



Your Solutions Partner

# Specifications

F.O.B. Sedalia, Missouri 65301



613-G2

(shown with optional casters)

### OPTIONS:

- Stainless steel interior
- Stainless steel back enclosure panel
- Seismic feet
- Common gas manifold
- 48" flexible disconnect, w/restraining device
- Down draft hood
- Flue deflector
- Casters
- Porcelain drip tray
- Double stack—shipped assembled
- Extra oven racks
- Prison package—tamper proof screws, lexan hinged cover with lockable clasp
- Extended warranty

**Approval Stamp(s):**

### PRODUCT INFORMATION:

PROJECT: \_\_\_\_\_

ITEM: \_\_\_\_\_

QUANTITY: \_\_\_\_\_

MODEL:

### Duke Convection Ovens

### Double Deck—Standard Depth—Gas

- 613-G2 Double deck, standard depth

### STANDARD FEATURES

- 6 racks/13 rack positions
- Porcelain interior finish
- 65/35 stainless steel dependent doors - chain driven
- Double pane glass in 65 door
- 8" angular painted legs/adjustable feet
- 2 speed motor

### OVEN SECTION

- Stainless steel front, sides and top
- 1 1/2" insulation on bottom, sides and back
- 3" insulation on top
- Interior Lights

### BURNER SYSTEM

- 40,000 BTU - each oven
- High output atmospheric burner system
- Main gas shut off valve
- Built-in gas regulator

### OVEN CONTROLS

- "V"—Basic snap action thermostat (200°-500°F), 60 minute electric dial timer with continuous sound buzzer, 2-speed fan
- "XX"—Solid state digital time and temperature controls, 12-hour countdown timer, **Cook and Hold** feature, 2-speed fan, Pulse fan capability

### DUKE MANUFACTURING CO.

2305 N. Broadway  
 St. Louis, MO 63102  
 800.735.3853 Toll Free  
 314.231.5074 Fax  
 www.dukemfg.com  
 SS-1071-613 G2-Double-Gas

### Certifications



Specification subject to change



REV C 09/25/2019

DUKE CONVECTION OVENS - DOUBLE - STANDARD DEPTH - GAS

Catalog No. DCO-GASDS

A.I.A. File No. 35-C-13

# DUKE CONVECTION OVENS

## DOUBLE DECK—GAS—STANDARD DEPTH

A.I.A. File No. 35-C-13

Catalog No. DCO-GASDS

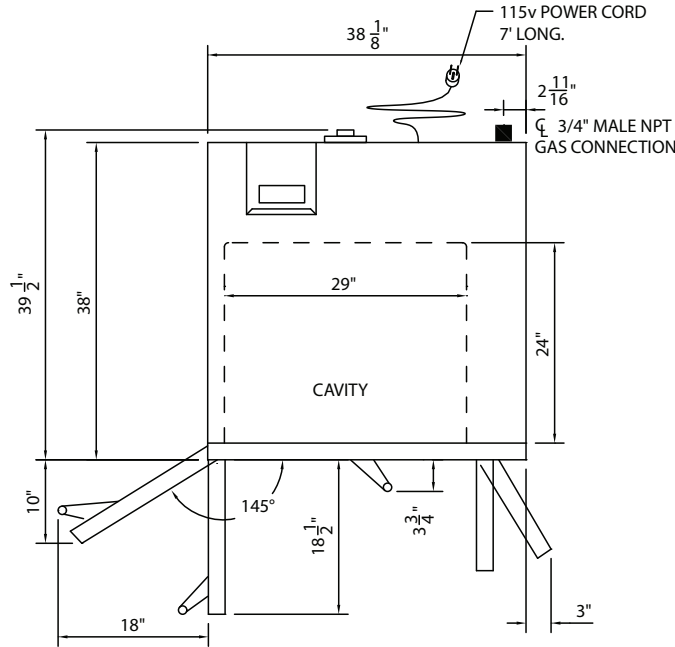

**TOP VIEW**

Gas Specifications		
<b>613-G2</b>	<b>BTU/Hour</b>	40,000
Regulated gas pressure required 3.5"WC natural /10" WC propane		
Combustible surface clearance - 1" side, 1" rear, 6" floor		
● Gas connection		
3/4" Gas connection		
Electrical requirements: 3.5 Amps/ 115V		
Standard 115V units supplied with 5' cord and plug		

Specify gas type  
Specify altitude over 2000 feet

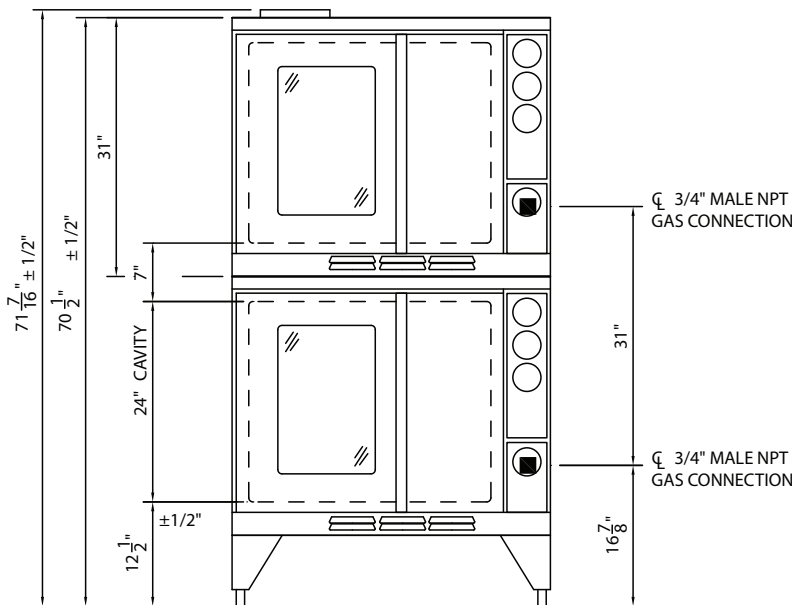

**FRONT VIEW**

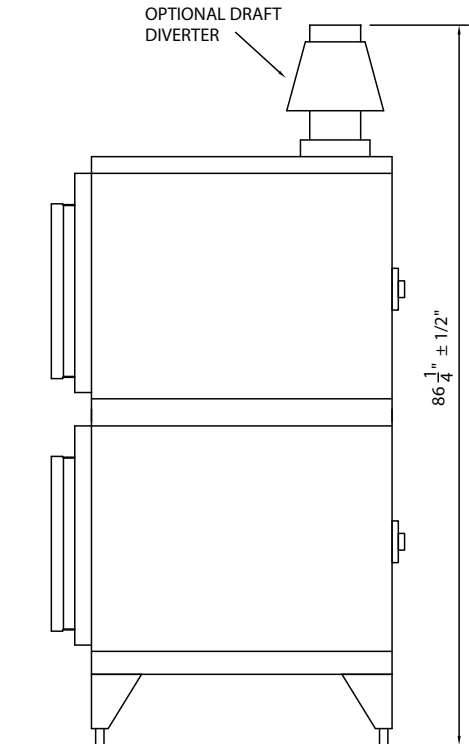

**RIGHT SIDE VIEW**

**DIMENSIONS:**

**Freight Class: 85**

Model	Height		Width		Depth		Cube ft. crated	Weight	
	in.	cm	in.	cm	in.	cm		lbs.	kg
<b>613-G2</b>	70 1/2	179.1	38	96.5	39 1/2	100.3	69.7	1080	491.0

DUKE CONVECTION OVENS- DOUBLE - STANDARD DEPTH - GAS



Your Solutions Partner

**Duke Manufacturing Co.**  
2305 N. Broadway  
St. Louis, MO 63102

Phone: 314-231-1130  
Toll Free: 1-800-735-3853  
Fax: 314-231-5074

[www.dukemfg.com](http://www.dukemfg.com)

Printed in U.S.A  
© 2019, Duke Manufacturing Co.