



Your Solutions Partner

Specifications

F.O.B. Sedalia, Missouri 65301



59-E3

OPTIONS:

- Stainless steel interior
- 4" or 6" stainless legs
- 8", 16", 27" stainless angular legs
- Casters
- Stainless steel open base with rack guides
- Extra Oven racks
- 8' or 11' cord and plug with receptacle
- High voltage (380/415/440/480)
- Pulse Fan option ("XX" controls only)
- Baking station stand on casters (**59-BS**)
- Proofer base (**PFB-1**)
- Extended warranty
- Optional shelf for leg stand
- Field stacking kit

DUKE MANUFACTURING CO.
 2305 N. Broadway
 St. Louis, MO 63102
 800.735.3853 Toll Free
 314.231.5074 Fax
 www.dukemfg.com
 SS-1060 Half Size Oven 59-E3

Approval Stamp(s):

PRODUCT INFORMATION:

PROJECT: _____

ITEM: _____

QUANTITY: _____

MODEL:

Duke Convection Ovens Single Section - Half Size - Electric

- **59-E3** 8.0 KW input per section

STANDARD FEATURES

- 5 racks/9 rack positions per oven
- Porcelain interior finish
- Single hinged door/door glass
- 4" plastic legs/adjustable feet
- 2 speed fan

OVEN SECTION

- Stainless steel front, sides and top
- 1" insulation on bottom, sides and back
- 3" insulation on top
- Interior lights

OVEN CONTROLS

- "V" - Basic snap action thermostat (200° - 500°F), 60 minute electric dial timer with continuous sounding buzzer, 2-speed fan
- "XX" - Solid state digital time and temperature controls, 12-hour countdown timer, **Cook and Hold** feature, 2-speed fan, Pulse fan capability

Certifications



DUKE CONVECTION OVENS - HALF-SIZE - SINGLE - ELECTRIC

Catalog No. DCO-1/2/ELECD5

A.I.A. File No. 35-C-13

Specification subject to change

REV 5-16-2019

DUKE CONVECTION OVENS

HALF SIZE—ELECTRIC—SINGLE SECTION

A.I.A. File No. 35-C-13

Catalog No. DCO-1/2ELECD5

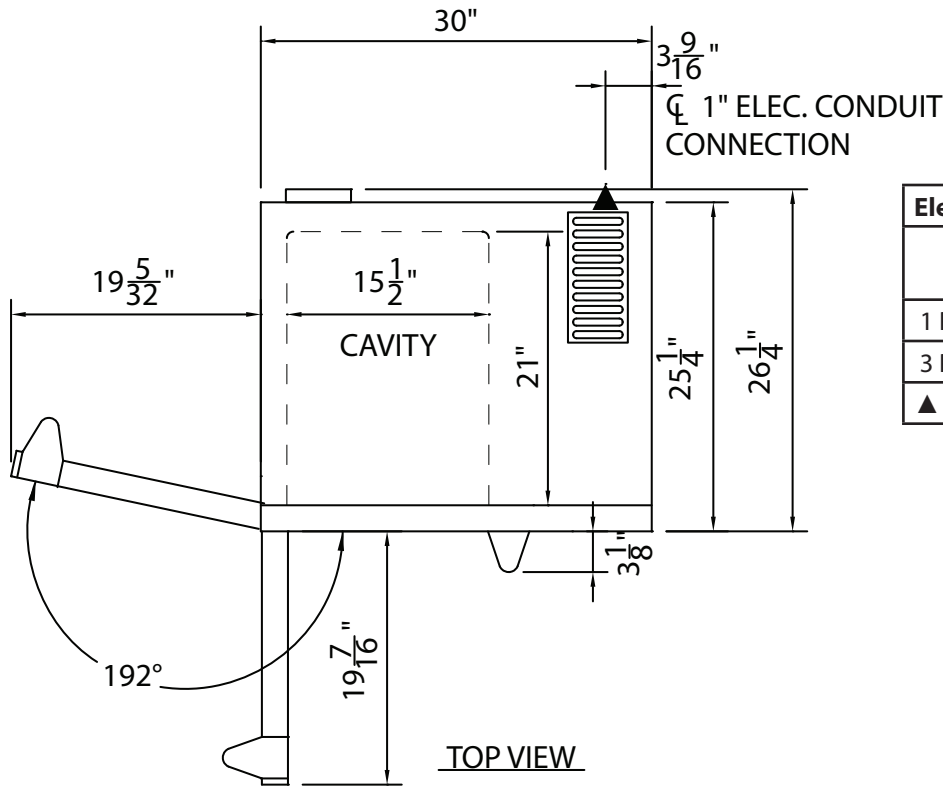

Electrical Specifications - Per Section			
	208V Amps	240V Amps	KW
1 Phase	40.0	35.0	8.0
3 Phase	24.0	21.0	8.0
▲ Electronic connection point			

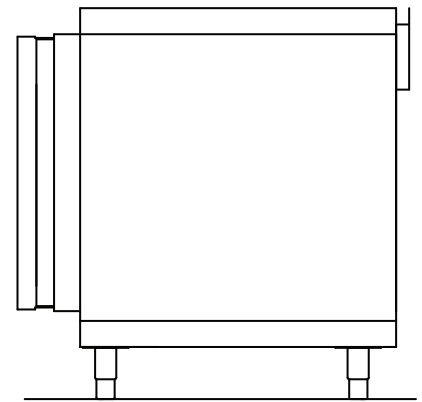
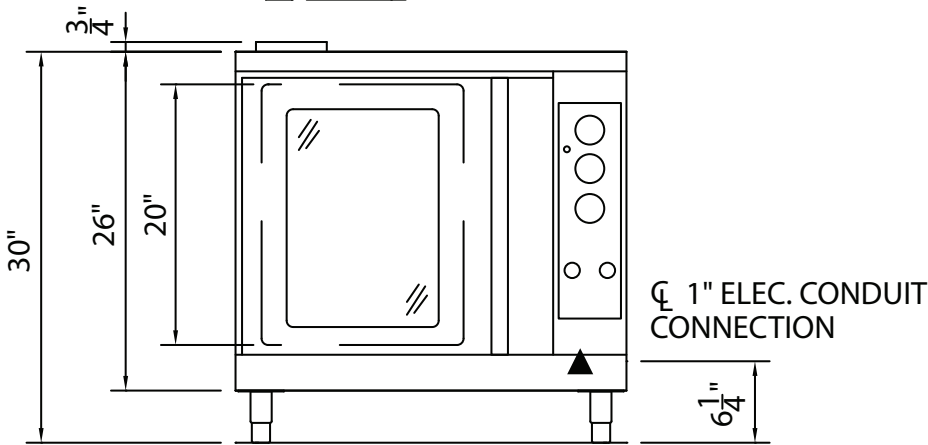

FRONT VIEW

RIGHT SIDE VIEW

DIMENSIONS:

Freight Class: 85

Model	Depth		Width		Height		Cube ft. crated	Weight	
	in.	cm	in.	cm	in.	cm		lbs.	kg
59-E3	25 1/4	64.1	30	76.2	30	76.2	24.3	265	120.5



Duke Manufacturing Co.
2305 N. Broadway
St. Louis, MO 63102

Phone: 314-231-1130
Toll Free: 1-800-735-3853
Fax: 314-231-5074

www.dukemfg.com